

Schottky Rectifier

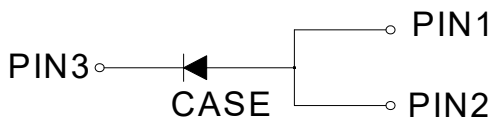
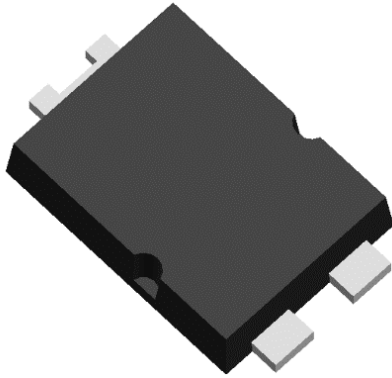

Features

- Ideal for automated placement
- Low forward voltage drop, low power losses
- High forward surge capability
- Part no. with suffix "Q" means AEC-Q101 qualified
- Meets MSL level1, per J-STD-020, LF maximum peak of 260 °C

Typical Applications

For use in lighting, fast switching rectification of power suppliers, inverters, converters, and freewheeling diodes for consumer, and telecommunication.

Mechanical Data

- **Package:** TO-277
Molding compound meets UL 94 V-0 flammability rating, RoHS-compliant, Halogen free
- **Terminals:** Tin plated leads, solderable per J-STD-002 and JESD22-B102

■ Maximum Ratings (T_a=25°C Unless otherwise specified)

PARAMETER	SYMBOL	UNIT	SS5U50PAQ	SS5U60PAQ
Device marking code			SS5U50PA	SS5U60PA
Repetitive Peak Reverse Voltage	V _{RRM}	V	50	60
Average Rectified Output Current @60Hz -sine wave (FIG.1)	I _O	A	5	
Forward Surge Current (Non-repetitive) @60Hz Half-sine wave, 1 cycle, T _a =25°C	I _{FSM}	A	200	
Current Squared Time @1ms≤t≤8.3ms T _j =25°C	I ² t	A ² s	166	
Storage Temperature	T _{stg}	°C	-55 ~+150	
Junction Temperature	T _j	°C	-55 ~+150	

■ Electrical Characteristics (T_a=25°C Unless otherwise specified)

PARAMETER	SYMBOL	UNIT	TEST CONDITIONS	Min	Typ	Max
Peak Forward Voltage	V _{FM}	V	I _{FM} = 5.0A, T _j = 25°C	-	-	0.64
			I _{FM} = 5.0A, T _j = 125°C	-	-	0.55
Reverse Breakdown Voltage	V _{BR}	V	I _R = 0.5mA	50	-	-
			I _R = 0.5mA	60	-	-
Leakage Current	I _R	mA	V _R = V _{RRM} , T _j = 25°C	-	-	0.15
			V _R = V _{RRM} , T _j = 125°C	-	-	20



SS5U50PAQ THRU SS5U60PAQ

■ Thermal Characteristics (T_a=25°C Unless otherwise specified)

PARAMETER		SYMBOL	UNIT	SS5U50PAQ / SS5U60PAQ
Thermal Resistance	Junction to Case	R _{θJ-C}	°C/W	8 ⁽¹⁾
Thermal Resistance	Junction to Ambient	R _{θJ-A}	°C/W	90 ⁽²⁾

Note

(1) Thermal resistance from junction to case mounted on P.C.B. with 16mm*16mm copper pad areas

(2) Thermal resistance from junction to ambient mounted on P.C.B. with 10mm*10mm copper pad areas

■ Ordering Information (Example)

PREFERRED P/N	PACKAGE CODE	UNIT WEIGHT(g)	MINIMUM PACKAGE(pcs)	INNER BOX QUANTITY(pcs)	OUTER CARTON QUANTITY(pcs)	DELIVERY MODE
SS5U50PAQ SS5U60PAQ	F1	Approximate 0.106	5000	10000	80000	13" reel

Marking Information

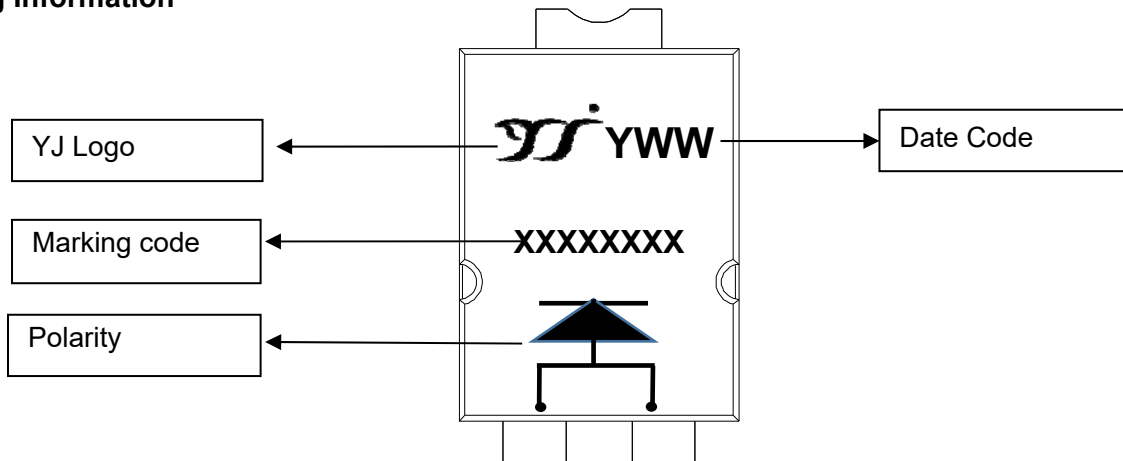

Note:

1. All marking is at middle of the product body
 2. All marking is in laser printing
 3. XXXXXX is marking code, like SS5U50PA
 4. Body color: Black
 5. YWW is date code, "Y" is year. "WW" is week.
- For instance: The 15th week of 2019, date code is 915



SS5U50PAQ THRU SS5U60PAQ

■ Characteristics (Typical)

FIG.1: I_o - T_c Curve

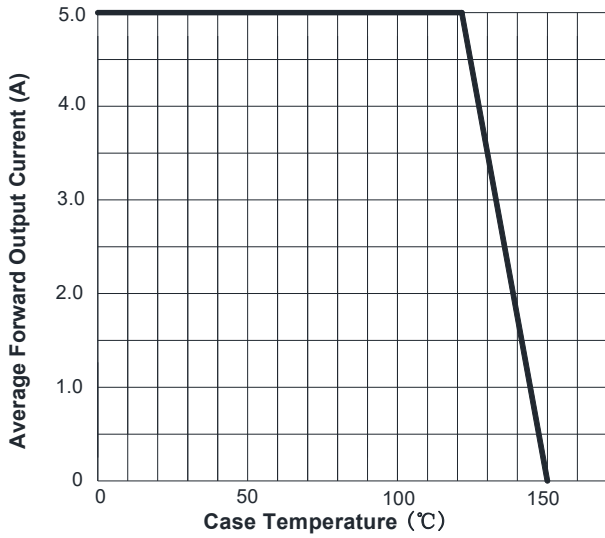

FIG.2: Forward Surge Current Capability

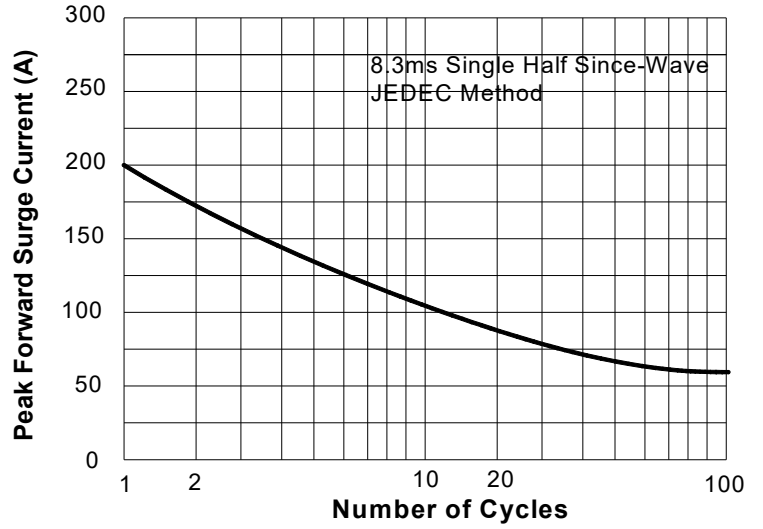

FIG.3: Forward Voltage

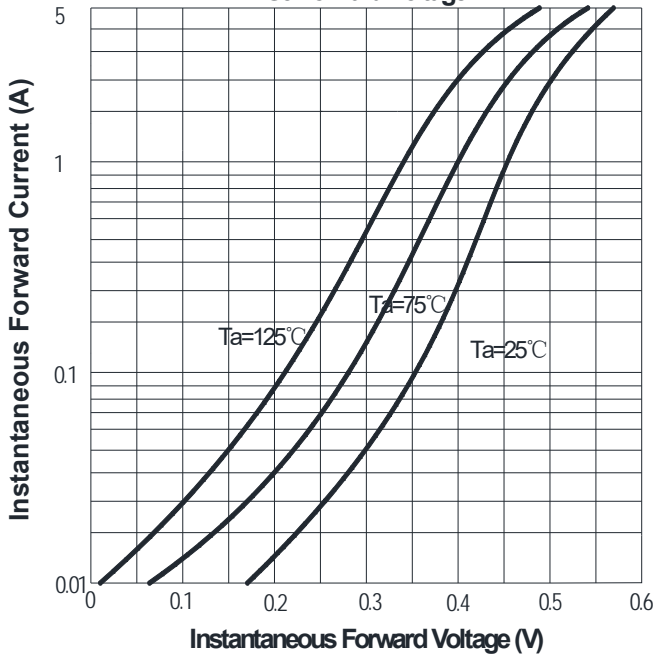
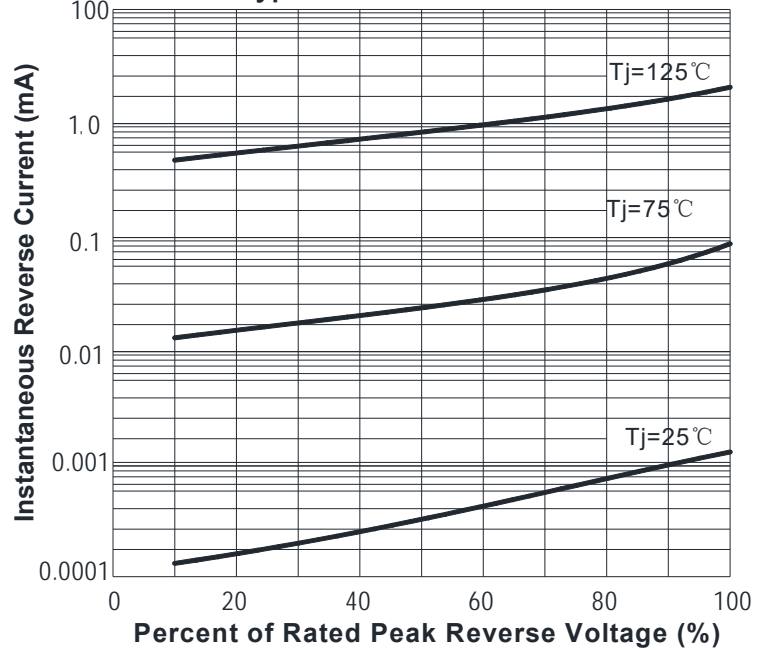

FIG.4: Typical Reverse Characteristics





SS5U50PAQ THRU SS5U60PAQ

■ Outline Dimensions

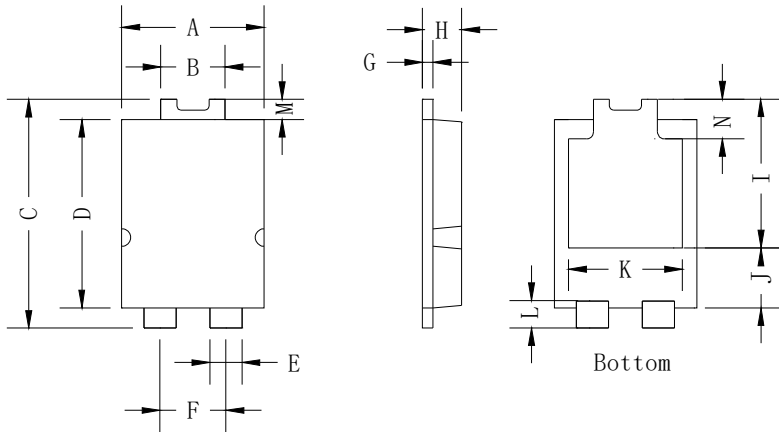

DIM	mm	
	MIN.	MAX.
A	3.90	4.10
B	1.70	1.90
C	6.40	6.60
D	5.30	5.50
E	0.80	1.00
F	1.85 ref.	
G	0.35	0.45
H	1.10	1.20
I	4.10	4.50
J	1.50	1.90
K	2.90	3.40
L	0.65	0.85
M	0.55 ref.	
N	1.15 ref.	

■ Suggested pad layout

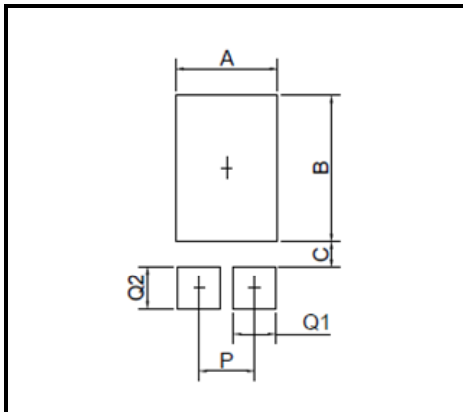

DIM	MIN.(mm)
A	3.36
B	4.86
C	0.85
P	1.84
Q1	1.40
Q2	1.40



SS5U50PAQ THRU SS5U60PAQ

Disclaimer

The information presented in this document is for reference only. Yangzhou Yangjie Electronic Technology Co., Ltd. reserves the right to make changes without notice for the specification of the products displayed herein to improve reliability, function or design or otherwise.

The product listed herein is designed to be used with automotive electronics, are not designed for use in medical, life-saving, lifesustaining, or military, Yangjie or anyone on its behalf, assumes no responsibility or liability for any damages resulting from such improper use of sale.

This publication supersedes & replaces all information previously supplied. For additional information, please visit our website [http:// www.21yangjie.com](http://www.21yangjie.com) , or consult your nearest Yangjie's sales office for further assistance.